



samex

PROFESSIONAL CUTTING EQUIPMENT

RollMaster Data Sheet

RollMaster

Roller blinds cutting table



Many years of experience in designing cutting tables allowed us to create a universal machine with unusual expansion and configuration options.

With this approach, we are able to adapt to very diverse needs of our clients without the need to design the customized device.

Additional accessories useful during the production process can be installed on the cutting table at any given moment as well as quickly disassembled.

RollMaster is available in three versions: Standard, Super and Premium. Each version has a different type of cutting device used, from manual cutter to ultrasonic knife.

The variety of configuration options makes it possible to choose cutting table systems for both start-ups and large companies with high production needs.

RollMaster is a versatile cutting table, which works perfectly when used for cutting material precisely to the size.

It is a perfect choice for roller blinds producers.

BASIC FEATURES

	RollMaster Standard	RollMaster Super	RollMaster Premium
CUTTING TABLE			
Cutting width	up to 270 cm	up to 320 cm	up to 350 cm
Length	200 – 500 cm		
Height	86-89 cm, regulated		
Frame	powder coated steel profiles		
Table top	25 mm, 2 mm PVC framed		
Colour scheme	blue/grey	blue/grey	black/orange

CUTTING DEVICE

Rotary cutter	manual	automatic	automatic
Ultrasonic cutter	-	-	yes
Cutting speed	-	1 m/s, optionally adjustable	0.8 m/s, adjustable
Cutting precision	1 mm		
Voltage	230 V		
Output power	130 W	200 W	1500 W
Protection equipment	blade covers	blade covers start lock with raised holding bar emergency switch	blade covers start lock with raised holding bar emergency switch

CONTROL FEATURES

Control panel	-	4-digit display, buttons	7" touch panel
Control buttons	-	2 sets	2 sets
Layer counter	yes	yes	yes
Setting the cutting length	-	yes	yes
Rotational speed adjustment	optional	optional	yes
Cutting speed adjustment	-	optional	yes
Cutter home position offset	-	-	yes
Advanced travel settings	-	-	yes
Statistics	-	-	yes
Languages	-	-	6

OTHER

Holding bar	pneumatic	pneumatic	pneumatic - double
Fabric feeder	upper/bottom	upper/bottom	upper

OPTIONAL EQUIPMENT

	RollMaster Standard	RollMaster Super	RollMaster Premium
Measuring device	slider with aluminium strip/slider with laser *		
LED backlight	-	optional	yes
Fabric rolling machine	yes, up to 38 mm tubes		
Control frame for rolling-up correctness	yes, up to 38 mm tubes, up to 250 cm width **		
Bottom shelves	optional	optional	optional
Additional assembly table	optional	optional	optional

* laser recommended for cutting width up to 250 cm

** different sizes on request

PHOTOS

CUTTER

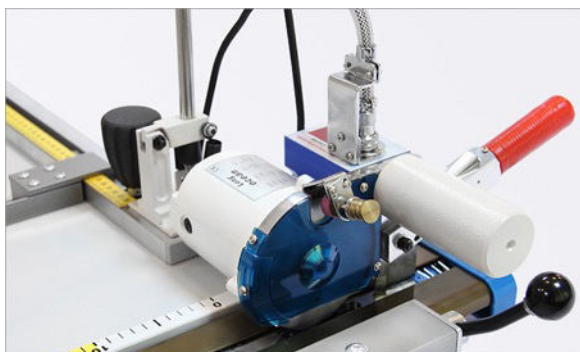

The Standard version equipped with a manual cutter

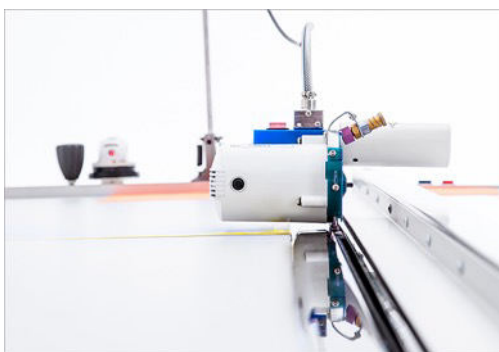

The Super version equipped with an automatic cutter

HOLDING BAR



Pneumatic holding bar operated with a button or a foot pedal

FABRIC FEEDER



Bottom version of a fabric feeder saves space if the room is small



Upper version of a fabric feeder makes it easier to unroll the material

FABRIC ROLLING MACHINE



It is useful to roll the material onto the tube



The side version allows installation on any side of the table

CONTROL FRAME FOR ROLLING-UP CORRECTNESS



Useful to check that the roller blind is rolled up correctly



The electric version is operated with a lever

BOTTOM SHELVES AND ASSEMBLY TABLE



Bottom shelves make a space for storing the rolls of fabrics



Additional table can be used to assembly the roller blinds

TECHNICAL DRAWINGS - EXAMPLES

RollMaster 280 Standard – length 250 cm

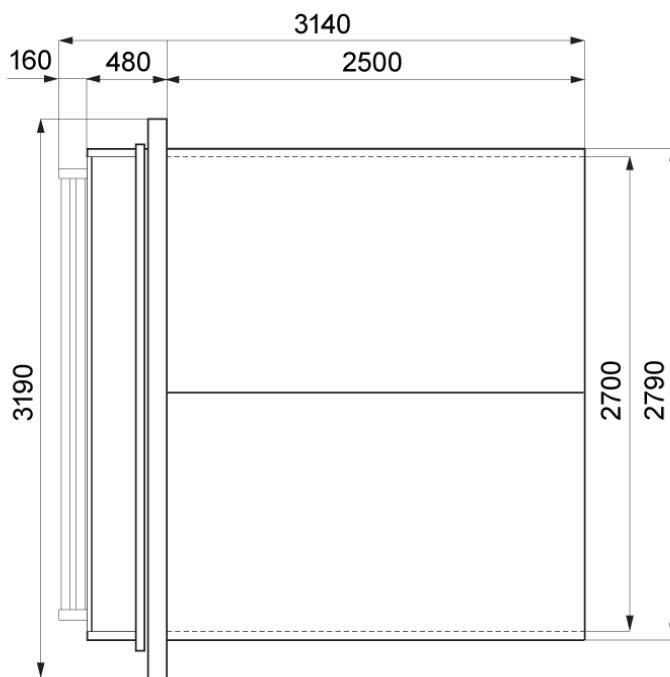

RollMaster 310 Super – length 350 cm

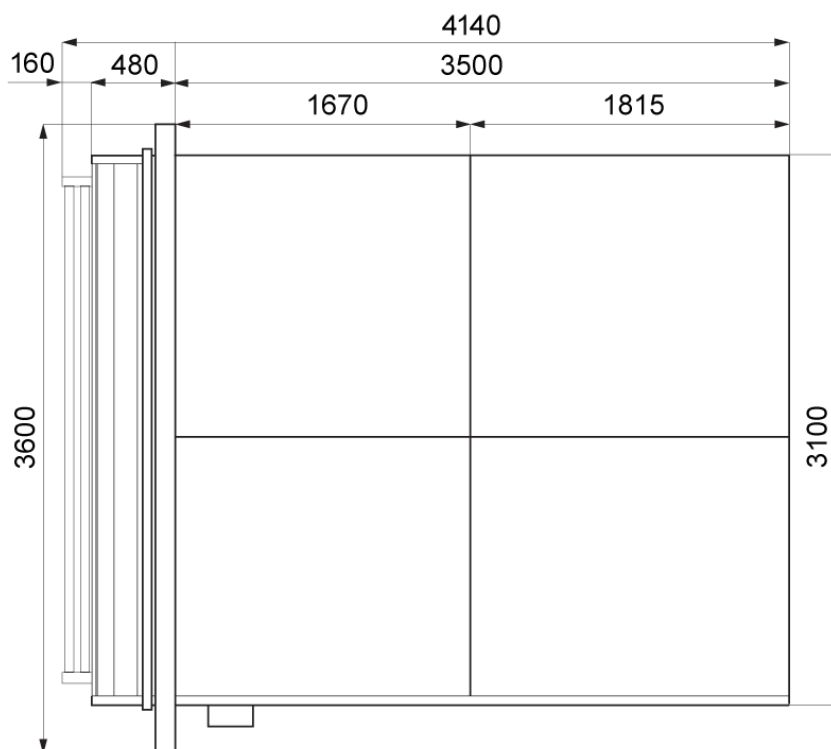

RollMaster 310 Premium – length 500 cm

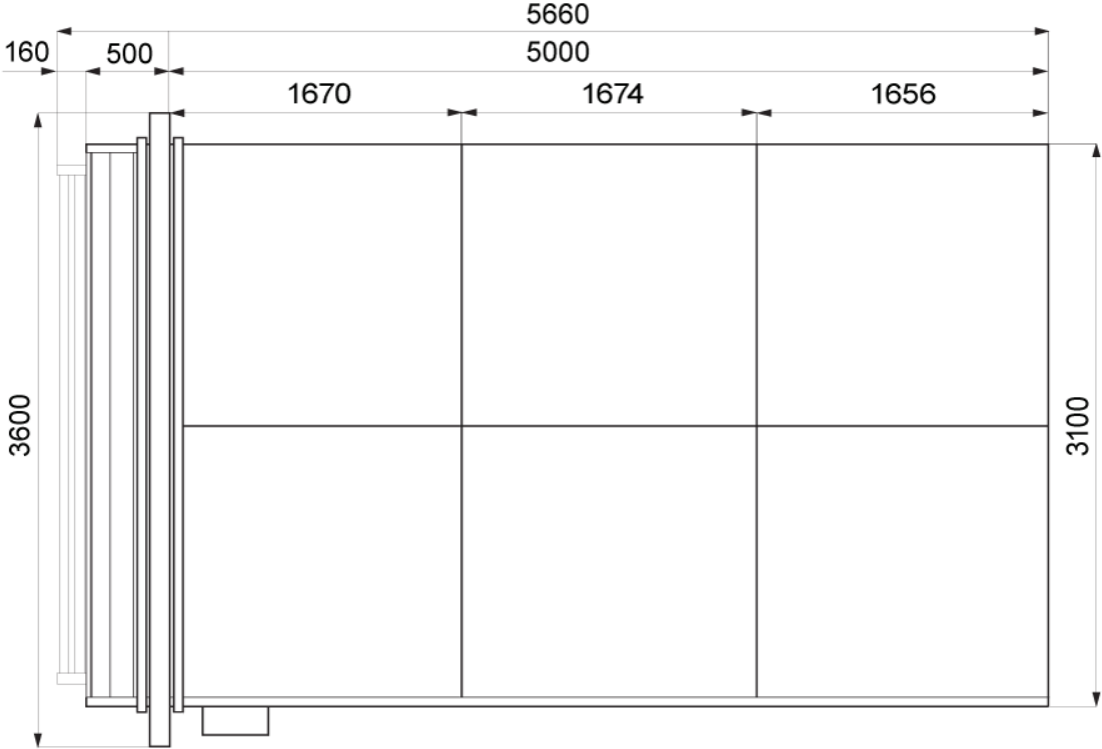



SAMEX Professional Cutting Equipment

93-160 Łódź, ul. Kilińskiego 300

Poland

+48 42 643 05 30

info@samex.com.pl

www.samex.com.pl

www.youtube.com/c/SAMEXPoland